

MSLR180 series (Single pump)



Product description

MSRL 180 series sewage lifting equipment is suitable for collecting sewage produced by toilet, basin, shower, sewage basin, bathtub, washing machine and so on, and pump it to the main sewage pipe or outdoor sewage well.
MSRL 180 series is equipped with a full range of pre water inlet. The volume of the box is about 180L. It is completely sealed and durable. It can meet different installation conditions.

Scope of application

It is suitable for foreign house, villa basement (with laundry), club, small public toilet, etc.

Performance curve

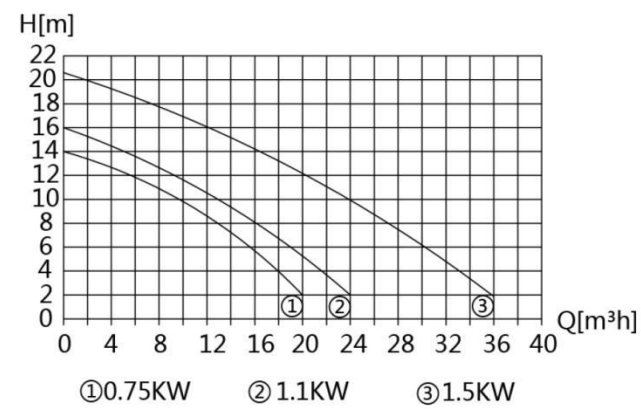

Performance parameter

- ※ Built in a cutting pump
- ※ Corrosion resistant PE box
- ※ The box is equipped with anchor interface
- ※ Fully closed, no odor emission
- ※ Water pump coupling connection, convenient maintenance
- ※ Multiple water inlets, convenient connection
- ※ Built in stainless steel check valve
- ※ The box is equipped with anchor interface
- ※ The size of the box is small and the application range is wide
- ※ Supporting special full LCD control box

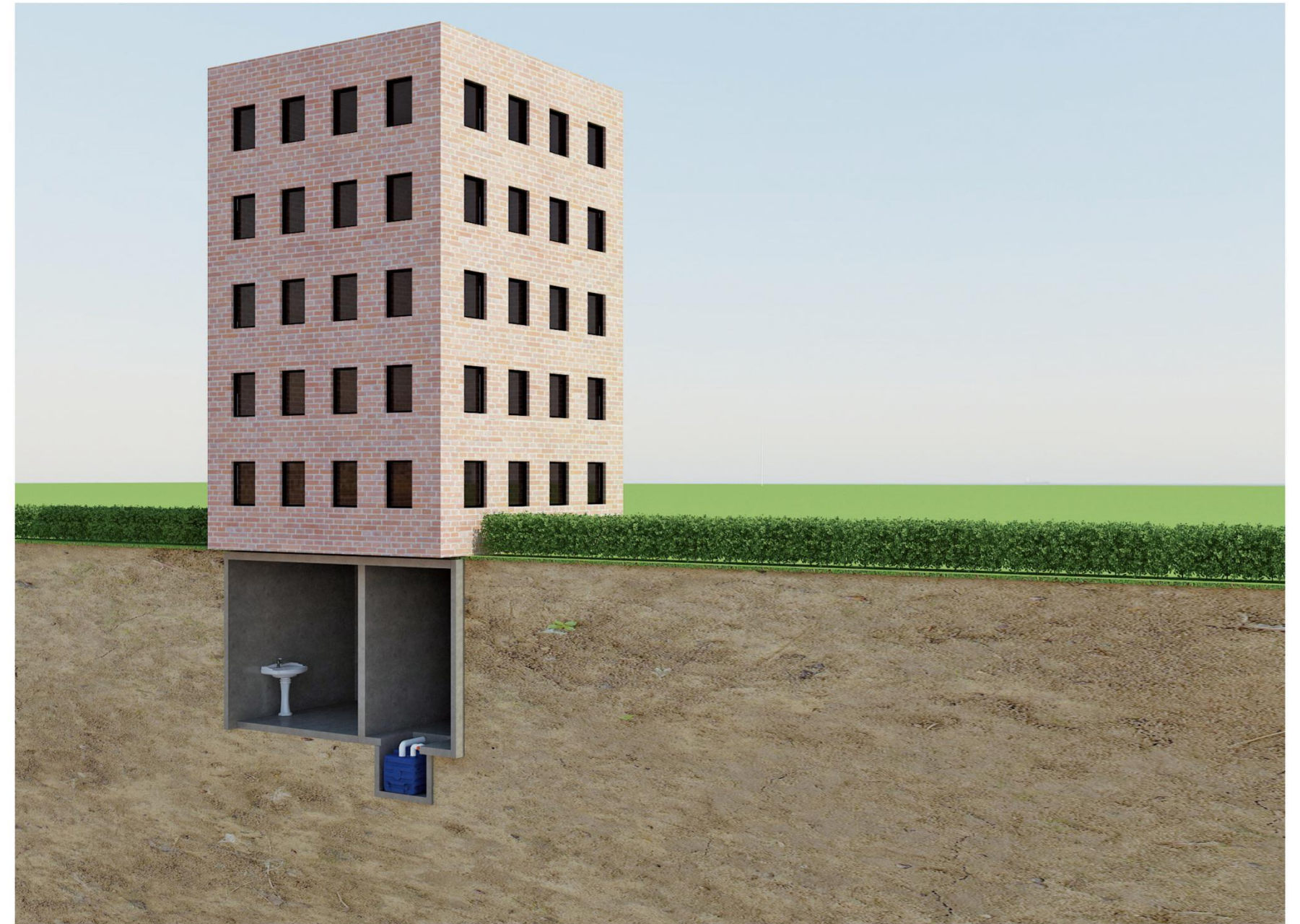

Technical parameter

Model	The volume of the collecting tank is about(L)	Intake	Outlet	Snorkel	Weight(kg)
MSLR180L075S	160	DN100	DN50	DN40	46
MSLR180L110S	160	DN100	DN50	DN40	47
MSLR180L150S	160	DN100	DN50	DN40	55

Selection table

Model	Power (KW)	Voltage (V)	Current (A)	Outlet diameter	Lift (m)	2	4	6	8	10	12	14	16	18	20	22	24	
MSLR180L075S	0.75	220	5.2	DN50	Flow (m ³ /m)	20	18	16	14	10	6							
MSLR180L110S	1.1	220	6.6			24	22	20	18	15	10	5						
MSLR180L150S	1.5	220	7.6			36	32	30	28	24	21	17	13	8				
MSLR180L075S	0.75	380	1.9			20	18	16	14	10	6							
MSLR180L110S	1.1	380	2.6			24	22	20	18	15	10	5						
MSLR180L150S	1.5	380	3.2			36	32	30	28	24	21	17	13	8				

Accessories list

Number	Description of accessories	Specification and size	Number	Remarks
1	controller	NK-1	1	Standard configuration
2	Ventilation soft connection	DN40	1	Standard configuration
3	Soft connection of water inlet	DN100	1	Standard configuration
4	Water inlet stop valve	DN100	1	Matching
5	Outlet stop valve	DN50	1	Matching
6	Stop valve of auxiliary pump outlet	DN40	1	Matching
7	Auxiliary pump	/	1	Matching

Equipment dimension drawing

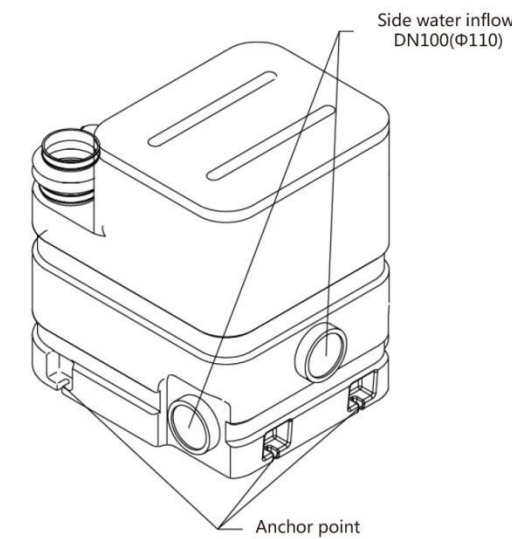
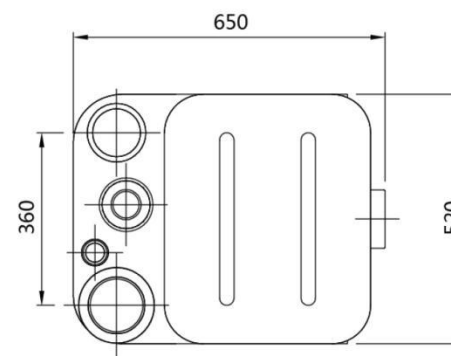
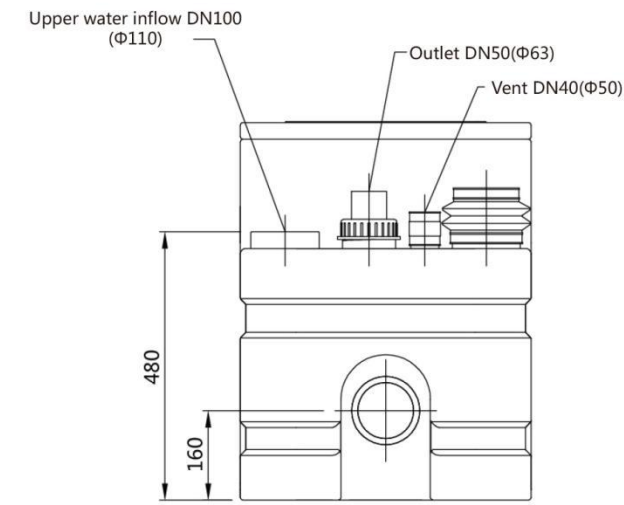
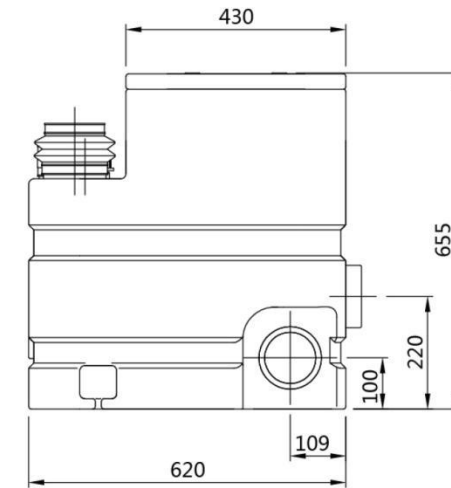

Installation diagram

